

## Perpendicular Steps Set Into the Wall Face



One of the unique benefits that sets Allan Block Retaining Wall Systems apart from other products is the great variety of options for designing and building steps. This example; **perpendicular steps set into the wall face**, requires no special blocks or cutting tools and is one of the easiest methods for building stairs. For other stair designs see [allanblock.com](http://allanblock.com).

### Before Getting Started

**Take The Time To Build In Quality** Building stairs and steps requires careful planning, flexibility on the job site and an eye for detail. Be sure to allow yourself a little extra time for laying out and building your stairs.

**Stair Tread Materials** Allan Block's patented raised front lip provides a built-in edging for a variety of tread materials including AB Capstones, landscape pavers, poured concrete, crushed rock, mulches and flagstones. Choose a tread material that best suits your stair application. This example shows the use of poured concrete for stair treads. If a rigid material such as AB Capstones or pavers is used, design the stair dimensions to minimize the required cutting of tread materials.

### Base Course

- Excavate a 6 in. deep x 18 in. wide (15 cm x 45.7 cm) base trench (Figure 1).
- Place 4 in. (10 cm) of granular material in the trench and compact with a mechanical plate compactor (Figure 1).
- Position the base course of AB Blocks as shown (Figure 3) and level them from side-to-side and front-to-back (Figure 2).
- Carefully place granular material in block cores and 6-12 in. (15-30 cm) behind the blocks. Compact to lock them in position (Figure 3). NOTE: The height of this backfill material should be level with the top of the base row of blocks. The next step's riser blocks will be placed on top of this material.

### 2nd Course

- Place the 2nd course riser blocks on top of the compacted backfill material. Position the AB blocks as shown (Figure 4) so that no cutting of blocks will be necessary. Level the blocks.
- Before adding the infill and backfill materials, place a small amount of gravel in front of the 2nd course blocks to hold them in place when backfilling and compacting (Figure 4).

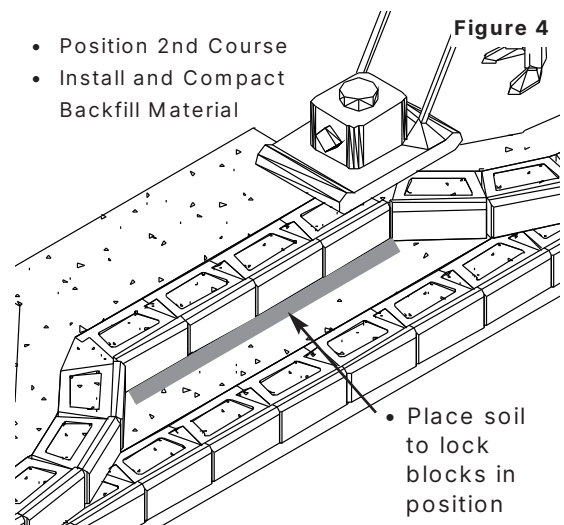
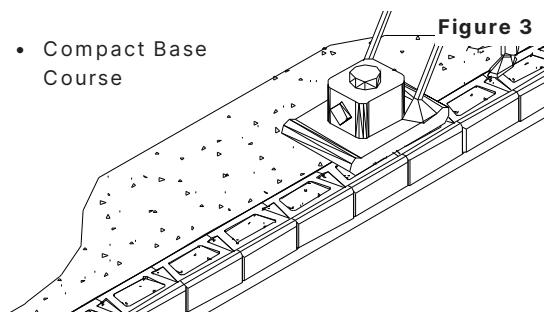
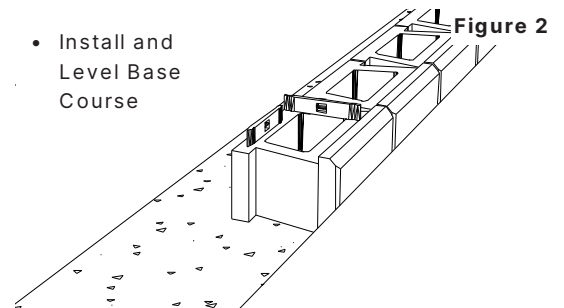
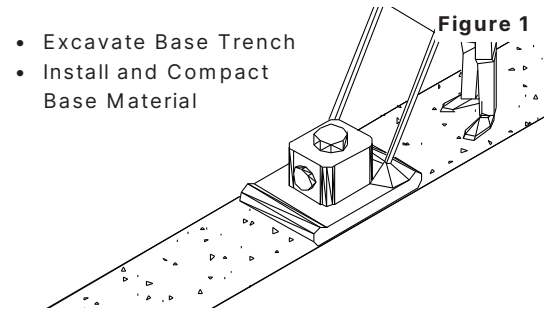

### 2nd Course Continued

- Place granular material in the 2nd course block cores and 6-12 in. (15-30 cm) behind the blocks.
- Fill in backfill soils behind the granular material.
- Taking care not to push the step blocks forward, compact the granular material and the infill soils behind the 2nd course to lock the blocks in position. The height of the compacted backfill material should be level with the top of the blocks in front of it (Figure 4).

### Additional Courses

- Repeat the above steps for each course of the stairs up to the top of the wall.
- Note that the width of the stairs decreases by full block increments with each of the first 3 steps. This eliminates the need to cut blocks.
- You can eliminate the need to cut blocks on subsequent steps by adjusting the stair width to meet the curves of the side walls.

### Stair Treads

- A variety of stair tread materials may be used to finish off your steps. If AB Capstones, landscape pavers or flagstones are used, the application of a construction adhesive is recommended to secure the treads in place.
- If a rigid dimension tread material is used such as AB Capstones or landscape pavers, carefully plan the stair dimensions to reduce the amount of cutting required.

**Note: If AB Capstones or poured concrete are used for stair treads, avoid the use of de-icing salts which will cause the concrete to deteriorate over time.**

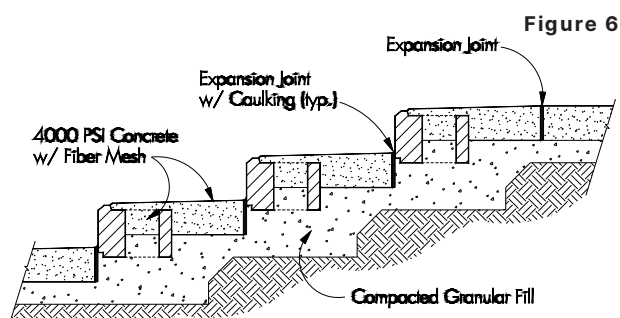
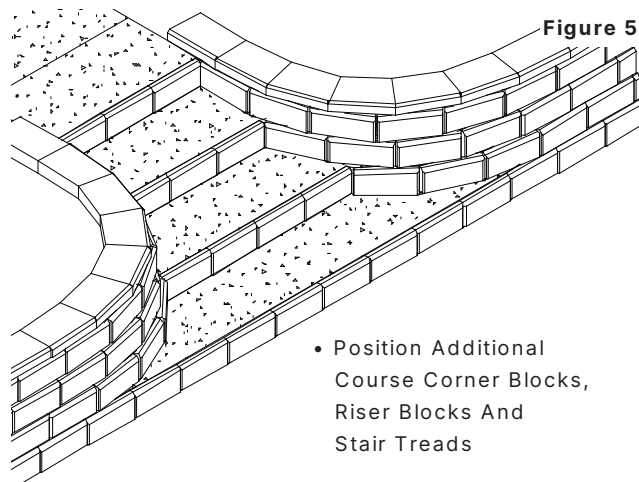

### Construction Notes

**GRANULAR BASE AND BACKFILL MATERIAL:** Allan Block recommends using the same material for the base, the drain field within the block cores and 6-12 in. (15-30 cm) behind the wall. We recommend a well draining compactible aggregate, ranging in size from 0.25 in. to 1.5 in. (6.4 mm to 3.8 cm) diameter. See your local aggregate sources for availability.

**COMPACTION:** Use a plate compactor to compact material in 8 in. (20 cm) lifts. First run the compactor on top of the block to lock them in position. Compact parallel to the wall, working from the front of the wall to the back of the infill material. Keep heavy equipment a minimum of 3 ft (0.9 m) from the back of the wall.

[allanblock.com](http://allanblock.com)

The information shown here is for use with Allan Block products only.

